

Entrust

leave it us

Automatic screw feeder
FK-505 Series
(Fixed rail width)

FK-505 Series



EASY and FAST

The automatic screw feeder for
enhancing efficiency and productivity.



FEEDKIDS

FK-505 Series (Fixed rail width)

- Supporting many screw and rail variations
 - Applicable screw head shapes
- FK-505 : standard screw
FK-505 is based on RoHS.

We have purchased the business relating to this product
From Sony EMCS Corporation as of March 31, 2013.

Entrust Corporation

◆ Model Line up Fixed rail width type

Model (FK-505 Standard screw)	Nominal screw size (d)	Screw length (L)			Maximum length
		Minimum length			
		Single screw	Screw with spring washer	Screw with spring + flat washer	
FK-514	1.4	1.4	—	—	18.0
FK-517	1.7	1.6	—	—	
FK-520	2.0	1.8	3.0	5.0	
FK-523 ※	2.3	2.5	4.0	5.0	
FK-526	2.6	2.8	4.0	6.0	
FK-530	3.0	3.0	4.0	6.0	
FK-535 ※	3.5	3.5	6.8	8.0	
FK-540	4.0	4.0	6.8	8.0	
FK-550	5.0	5.0	8.0	10.0	

※All products are manufactured upon receipt of orders. For delivery dates, please make inquiries to below sales agents.

(Unit : mm)

◆ Available screw type

FK-505 Series	
Nominal screw size	9 rail variations (1.4~5.0)
Screw type	Machine screw, Tapping screw
Shape of screw head (+ shaped screw top)	JCIS:Pan-head Type1, Type2, Type3 JIS : Pan-head, binding, truss, brazier, flat, pan-head with collar, w/t spring washer and washer
Material	Ferrum, or material attaching to magnet

※Caution : Please note no correspondence to the screw other than the above-mentioned.

◆ Specifications

FK-505 Series	
input Voltage	DC12V 200mA
AC adaptor (SQN30W 12P-13)	AC100-240V 50/60Hz 12V. 2.5A AC cable (accessory)
DC plug	EIAJ Type
Outside dimentions	120 (W) × 155 (D) × 137 (H) mm
Mass (Main unit only)	FK-505 1.1kg
Continuous screw supply speed	Aplox. 1.5 sec per one screw (+PM 3.0×8)
screw transfer method	Inclined rail type
Working environment	+10 ~ +30°C (no condensation), Less than 1,000m above sea level
Storage temperature	+10 ~ +50°C (no condensation)
Noise level	66 db
Operating Environment	Indoor use only

◆ Dimentions

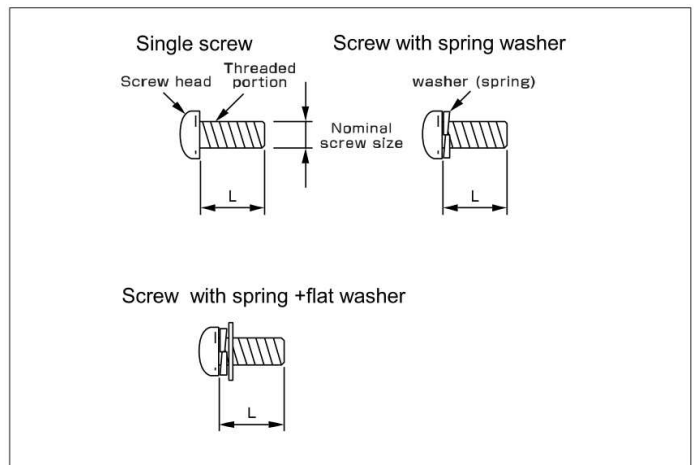
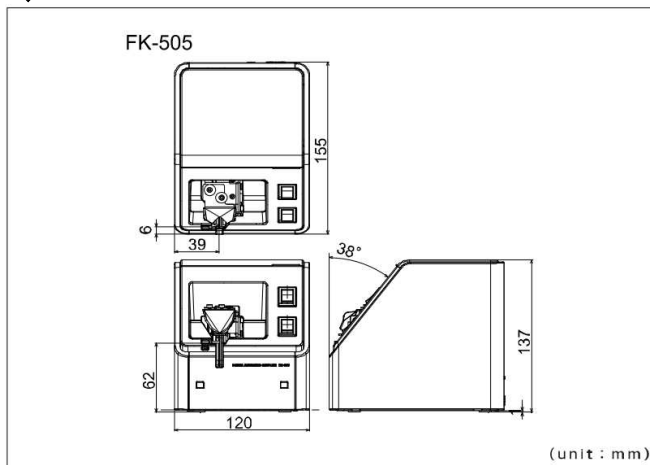

⚠ Safety Precautions : To use the product safety, read and understand the contents of the instruction manual before use.

●Standard, specifications and appearance are subject to change due to continual improvements without prior notice.

●Indicating below is for use in European countries.

This apparatus intended for use in industrial environments. The apparatus shall not be used in the residential, commercial and light-industrial environment.

It must not be connected to public power supply systems. It is only intended for use inside industrial power supply network.

Distributor

Entrust Corporation

【Entrust international (Hong Kong) Co.,Ltd】

Unit 807, 8/F, Fo Tan Industrial Centre, No.26-28

Au Pui Wan Street, Fo Tan, Shatin, New Territories-Hong Kong

tel. +852-3521-0916 fax. +852-3521-0915

【Head Office】

6F, 1-25-13, Higashigotanda, Shinagawa-ku, Tokyo,

141-0022, Japan

<http://entrust-group.co.jp>